

# ICC Evaluation Report





Issued November 2022

This report is subject to renewal November 2023.

## DIVISION: 07 00 00—THERMAL AND MOISTURE PROTECTION

### Section: 07 40 00 – Roofing and Siding Panels

#### REPORT HOLDER:

ISOCINDU SA DE CV

#### EVALUATION SUBJECT:

ISOPARETE INSULATED METAL WALL PANELS  
(BOX, PLISSÉ, PIANO)  
ISOCOP4 INSULATED METAL ROOF PANELS

## 1.0 EVALUATION SCOPE

### Compliance with the following codes:

- ▶ 2021, 2018, 2015, and 2012 International Building Code® (IBC)

### Properties evaluated

- ▶ Structural
- ▶ Fire (Surface Burning Characteristics and Roofing Classification)

For evaluation for compliance with codes adopted by the California Office of Statewide Health Planning and Development (OSHPD) and Division of State Architects (DSA), see [ESR- 4659 CBC and CRC Supplement](#).

## 2.0 USES

Isoparete Insulated Metal Wall Panels are used as interior or exterior nonload - bearing wall panels. The panels are for interior or exterior use at locations where Type V-B (combustible, nonfire-resistance-rated) building construction is permitted by the IBC.

Isocop4 Insulated Metal Roof Panels are used as structural roof panels. The panels are for use in locations where Type V-B (combustible, nonfire-resistance-rated) building construction is permitted by the IBC.

## 3.0 DESCRIPTION

### 3.1 General:

**3.1.1 Isoparete Panels:** The Isoparete Insulated Metal Wall Panels are factory assembled sandwich panels with galvanized steel facers and a self-adhering continuously foamed-in-place polyisocyanurate (PIR) rigid cellular plastic.

foam core . The panels are manufactured with a single interior profile, multiple exterior panel facer architectural profiles, and a tongue and groove configuration on the sides of the panels. The Isoparete panels are available in nominal thicknesses of 2, 2½, 3, 4, 5, 6 and 8 inches (51, 64, 76, 102, 127, 152 and 203 mm), a nominal width of 39¾ inches (1000 mm), and lengths of up to 56 feet (17.1 m). The panels can be installed in either vertical or horizontal orientations. The Isoparete panels are available in the thicknesses and profiles noted in Table 1; architectural profiles are shown in Figure 1.

**3.1.2 Isocop4 Roof Panels:** The Isocop4 Insulated Metal Roof Panels are factory assembled sandwich panels with galvanized steel facers and a self-adhering continuously foamed-in-place polyisocyanurate (PIR) rigid cellular plastic foam core. The panels are manufactured with trapezoidal ridges on the exterior face. The Isocop4 Panels are available in nominal thicknesses of 2, 2½, 3, 4, 5, 6 and 8 inches (51, 64, 76, 102, 127, 152 and 203 mm), a nominal width of 39¾ inches (1000 mm), and lengths of up to 56 feet (17.1 m). The Isocop4 Insulated Metal Roof Panels are available in the thicknesses noted in Table 1 and the interior and exterior profiles are as shown in Figure 1.

### 3.2 Material:

**3.2.1 Panel Facers:** Panel facings for Isoparete and Isocop4 panels are fabricated from No. 26 or No. 24 gauge [0.0187 or 0.023 inch (0.475 or 0.599 mm), respectively, base metal thickness] steel conforming to ASTM A653 SS Grade 37 with a Class G90 galvanized coating. The panel facings are available with various Polyvinylidene Fluoride (PVDF) coating finishes, as specified in the manufacturer's quality documentation.

**3.2.2 Panel Cores:** The foam plastic cores of the panels are polyisocyanurate (PIR) rigid cellular foam with a nominal density of 2.25 pounds per cubic foot (36 kg/m<sup>3</sup>). The panel cores have a flame-spread index of 25 or less and a smoke-developed index of 450 or less when tested in accordance with ASTM E84 at 4 inches. The foam core is continuously foamed in place to form the core of the panel during panel fabrication.

### 3.2.3 Connections:

**3.2.3.1 Isoparete Wall Panel Saddle Clips:** The wall panel saddle clips are used along with the project-specific fasteners to attach wall panels to the supporting framing at the tongue and groove panel joint. The saddle clips are fabricated from No. 14 gauge [0.0625 inch (1.59mm), base metal thickness] steel conforming to ASTM A653 SS

37 with a Class G90 galvanized coating (See Figure 3).

**3.2.3.2 Isocop4 Roof Panel Saddle Clips:** The roof panel saddle clips are used along with the project-specific fasteners and gaskets to attach the roof panels to the supporting framing at the panel joints. The saddle clips are fabricated from No. 16 gauge [0.0575 inch (1.46 mm), base metal thickness] steel conforming to ASTM A653 SS Grade 37 with a Class G90 galvanized coating; the clips are color-matched to the roof panels using various Polyvinylidene Fluoride (PVDF) coating finishes, as specified in the manufacturer's quality documentation (see Figure 4).

**3.2.3.3 Panel Fasteners:** Fastening of the panels to the various types of building substrates is outside the scope of this report and shall be designed by a Registered Design Professional and submitted to the code official. Fasteners must have a minimum head diameter of 5/8 inch (15.9 mm), a minimum thread diameter of 1/4 inch (6.4 mm) and must be corrosion-resistant.

**3.2.4 Flashing:** Flashing material must be No. 26 gauge [0.0187 inch (0.475 mm)] thickness and corrosion resistant.

**3.2.5 Sealant:** Non-skinning butyl sealant is used for panel joints and trim. Sealants must conform to AAMA Voluntary Specification and Test Methods for Non-drying Sealants (AAMA 809.2-92). The sealant is applied to clean and dry surfaces at temperatures ranging from 40°F to 120°F (5°C to 49°C).

## 4.0 DESIGN AND INSTALLATION

**4.1 Design:** An analysis must be submitted to the code official demonstrating that the panel system, including project-specific fasteners and structural framing members, provides a complete load path capable of transferring all loads and forces from their point of origin to load-resisting elements. Structural supports must provide a minimum bearing width of 1.5 inches (38.1 mm) to the panels, unless otherwise justified by registered design professional. The panels can be installed with the maximum spans and maximum allowable uniform loads, as noted in Tables 2 and 3, as applicable.

### 4.2 Installation:

#### 4.2.1 Isoparete Wall Panels:

Wall panels can be installed in either the horizontal or vertical direction. Individual panels may span one, two, or more spans. When the panels are installed in the horizontal orientation, they are installed from bottom to top with the female tongue and groove pocket on the bottom. When the panels are installed in the vertical orientation, they may be installed from either right to left or from left to right with the male edge leading. The panels must be fastened to the structural supports by means of a saddle clip and panel fastener. The fasteners and clips are installed along the male edge of the panels (see Figure 2). Saddle clips must be as described in accordance with Section 3.2.3.1 of this report.

The continuous butyl sealant in accordance with Section 3.2.5 is field applied to tongue and groove joints during installation.

During erection, the side joints of the panels are interlocked such that there is continuous contact between the butyl sealant and the adjacent panels. Erection proceeds along the wall elevation, with the installation of successive panels being in accordance with the manufacturer's installation instructions.

Provided the sealant and application of the sealant are satisfactory to the code official, panels exposed to weather do not require a weather-resistive barrier in accordance with Section 1404 of the 2021 and 2018 IBC (Section 1405 of 2015 and 2012 IBC); panels must be installed with sealant specified in Section 3.2.5, and wall openings and penetrations must be flashed. Flashing must be placed in accordance with 2021 and 2018 IBC Section 1404.4 (2015 IBC Section 1405.4 or 2012 IBC Section 1405.3) on both ends of the panels when installation is at the building's base, and at eaves, openings, and horizontal and vertical corners. The flashing is attached to the panels with rivets or self-tapping screws in accordance with the published Isocindu installation guide.

### 4.2.2 Roof Panels:

**4.2.2.1 Isocop4 Roof Panels:** Isocop4 panels are installed at a minimum slope complying with the requirements for standing seam roof systems in Section 1507.4.2 of the IBC and are attached to structural members by means of roof panel saddle clips and roof panel fasteners with gaskets. The fasteners and clips are installed along the edge of the panels in an exposed condition (see Figure 5). Butyl sealant is placed at each underlying panel side lap before the adjacent panel covers the joint. The fastener pattern must be as shown in Figure 6. The saddle clips must be in accordance with Section 3.2.3.2 of this report.

### 4.3 Additional Considerations:

Isocop4 roof panels installed across spaced steel supports without coverings are Class A roof covering assemblies when tested in accordance with ASTM E108. The fasteners must be of sufficient length to penetrate through the panel skins to the supporting structure. Flashing must be installed in accordance with the IBC.

For all roof and wall panels described in this report, a thermal barrier is required to be installed in accordance with Section 2603.4 of the IBC, unless the final installation is in accordance with Section 2603.4.1 of the IBC.

### 4.4 Allowable Load Capacity:

The allowable positive and negative out-of-plane (transverse) loads for panels are based on panel stiffness, thickness and strength as set forth in Tables 2 and 3. The fastener capacity in the applicable substrate is outside of the scope of this report.

## 5.0 CONDITIONS OF USE

The Isoparete and Isocop4 panels described in this report comply with, or are a suitable alternative to what is specified in, those codes listed in Section 1.0 of this report, subject to the following conditions:

**5.1** Panels must be installed in accordance with this report and the manufacturer's published installation instructions, a copy of which must be available at the jobsite. In the event of a conflict between this report and the manufacturer's published installation instructions, the more restrictive governs.



- 5.2 Isoparete wall panels must be limited to nonload-bearing applications.
- 5.3 Isocop4 roof panels must be limited to applications in which design uniform live loads are 20 psf (958 Pa) or less and design concentrated live loads are 300 pounds (1.33 kN) or less.
- 5.4 A thermal barrier is required to be installed in accordance with Section 2603.4 of the IBC, unless the final installation is in accordance with IBC Section 2603.4.1.
- 5.5 Use of Isoparete wall panels in areas where the probability of termite infestation is “very heavy” must be in accordance with Section 2603.8 of the 2021, 2018 and 2015 IBC (Section 2603.9 of the 2012 IBC)
- 5.6 Remaining portions of the structure other than the panels described in this report must be designed and constructed in accordance with the code.
- 5.7 Construction plans, calculations for the actual loading conditions and calculations for the connection of the metal panels to the supporting members must be submitted to the code official for approval.
- 5.8 All construction documents specifying the panels described in this report must comply with the design limitations of this report.

The drawings and design details must be prepared by a registered design professional where required by the statutes of the jurisdiction in which the project is to be constructed.

5.9 The panels must be fabricated by Isocindu SA DE CV at their manufacturing plant under a quality program with inspections by ICC-ES.

**6.0 EVIDENCE SUBMITTED**

Data in accordance with the ICC-ES Acceptance Criteria for Sandwich Panels (AC04), dated June 2019 (editorially revised December 2020).

**7.0 IDENTIFICATION**

7.1 The Isocop4 panels described in this report are identified by a label on the panels bearing the manufacturer’s name and the ICC-ES evaluation report number (ESR-4659).

7.2 The report holder’s contact information is the following:

ISOCINDU SA DE CV  
 AV LIBRE COMERCIO 137  
 PUERTO INTERIOR SANTA FE iii  
 SILAO, GUANAJUATO, MEXICO 36275  
 +52 472 800 7241  
 www.iscocindu.com

**TABLE 1 – PANEL PROFILES AND THICKNESSES**

PANEL DESIGNATION	PROFILE <sup>1</sup>		THICKNESSES
	Exterior	Interior	
Isoparete	Box, Plissé, Piano	Minor Rib	2, 2½, 3, 4, 5, 6 and 8 inches
Isocop4	Trapezoidal Ridge	Minor Rib	2, 2½, 3, 4, 5, 6 and 8 inches

For SI: 1 inch = 25.4 mm..  
 See Figures 1 and 2 for profiles

**TABLE 2 – ALLOWABLE TRANSVERSE LOADS FOR ISOPARETE WALL PANELS (L/180) (psf)<sup>1,2,3</sup>**

PANEL THICKNESS (inches)	SINGLE SPAN			MULTIPLE SPAN (TWO OR MORE SPANS)		
	Support Spacing (max)			Support Spacing (max)		
	≤ 48 inches	72 inches	96 inches	≤ 48 inches	72 inches	96 inches
2	19.6	12.0	-	15.7	9.6	-
2.5	19.5	12.1	-	15.6	9.7	-
3	19.4	12.3	9.9	15.5	9.8	-
4	19.1	12.5	10.9	15.3	10.0	-
5	18.9	12.8	11.8	15.1	10.2	-
6	18.7	13.0	12.7	14.9	10.4	10.2
8	18.2	13.5	14.6	14.6	10.8	11.7

For SI: 1 inch = 25.4 mm; 1 psf = 47.88 Pa.

<sup>1</sup> Wind pressure values are based on panels having minimum No.26 gauge steel facing liners on both faces

<sup>2</sup> The allowable loads are based on the lesser of deflection and panel strength, with consideration of the effects of fastener-location and fastener-to-panel connection on the allowable negative loads.

<sup>3</sup> See Figure 2 for panel fastening details.



**TABLE 3 – ALLOWABLE TRANSVERSE LOADS FOR ISOCOP4 ROOF PANELS (L/240) (psf)<sup>1,2,3</sup>**

PANEL THICKNESS (inches)	SINGLE SPAN						MULTIPLE SPAN (TWO OR MORE SPANS) <sup>4</sup>					
	Support Spacing (max)						Support Spacing (max)					
	≤ 48 inches		72 inches		96 inches		≤ 48 inches		72 inches		96 inches	
	Negative	Positive	Negative	Positive	Negative	Positive	Negative	Positive	Negative	Positive	Negative	Positive
2	73	88	37	37	24	26	58	70	30	30	19	21
2.5	74	107	39	50	26	36	59	85	32	40	21	29
3	75	125	41	62	28	46	60	100	33	50	22	37
4	78	163	44	88	32	66	62	130	35	70	26	53
5	80	201	47	113	36	85	64	160	38	90	29	68
6	83	238	51	138	40	105	66	190	41	111	32	84
8	88	313	57	189	48	144	70	251	46	151	39	115

For SI: 1 inch = 25.4 mm; 1 psf = 47.88 Pa

<sup>1</sup> Wind pressure values are based on panels having minimum No.26 gauge thickness steel facing liners on both faces

<sup>2</sup> The allowable loads are based on the lesser of deflection and panel strength in the positive or negative direction, with consideration of the effects of clip-location and clip-to-panel connection on the allowable negative loads; project specific fasteners must be checked for compatibility with this chart in the approved engineering calculations.

<sup>3</sup> See Figures 5 and 6 for panel fastening details.

<sup>4</sup> Two or more spa.

**TYPES OF PANELS**

*Isoparete box*

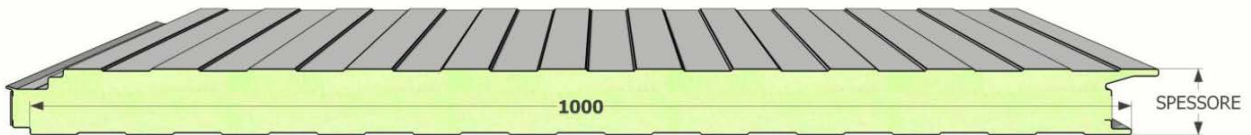

*Isoparete plissé*

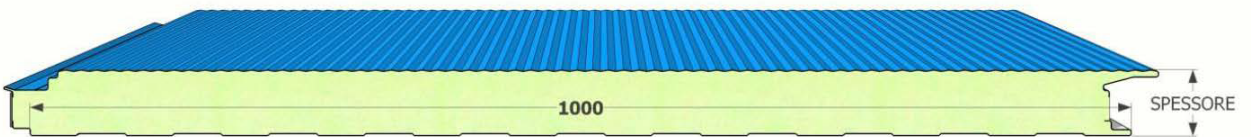

*Isoparete piano*

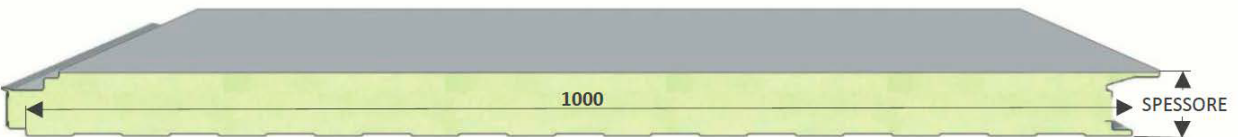

Dimensions are in mm; for SI: 1 inch = 25.4 mm

**FIGURE 1 – ISOPARETE PANEL FACER PROFILES**

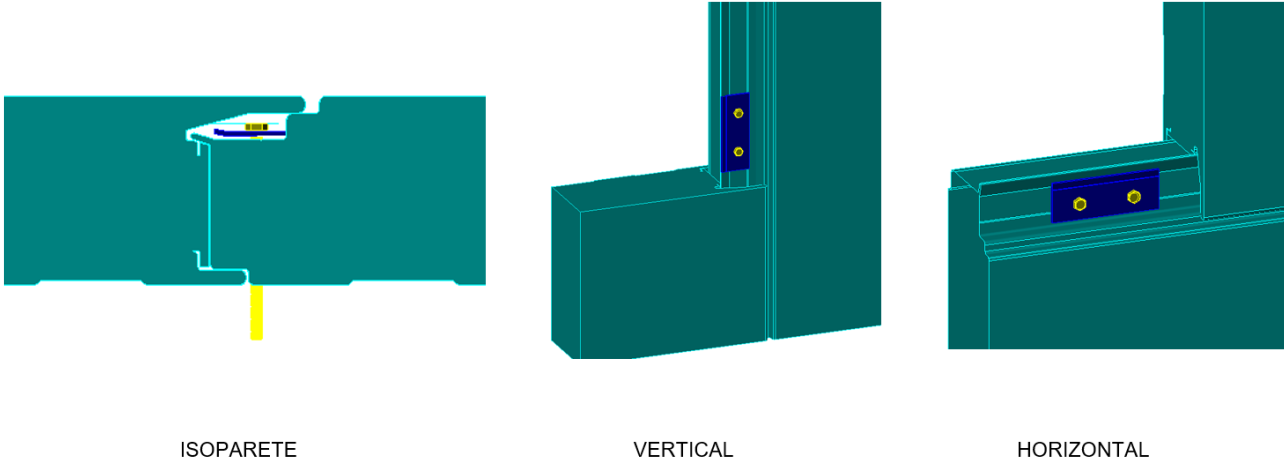

FIGURE 2 – ISOPARETE PANEL ATTACHMENT DETAILS

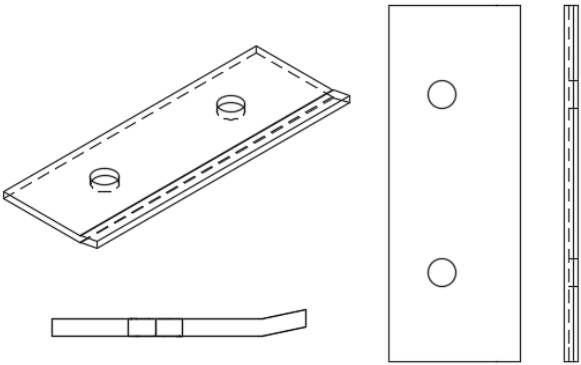
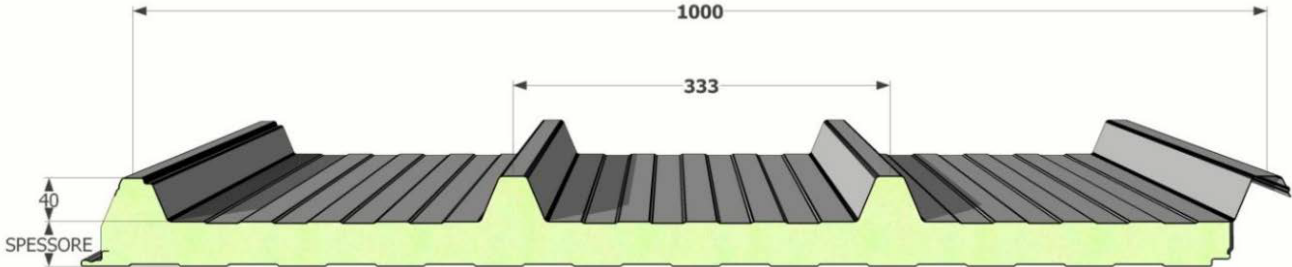

FIGURE 3 – ISOPARETE SADDLE CLIP



Dimensions are in mm; for SI: 1 inch = 25.4 mm

FIGURE 4 – ISOCOP4 PANEL PROFILE

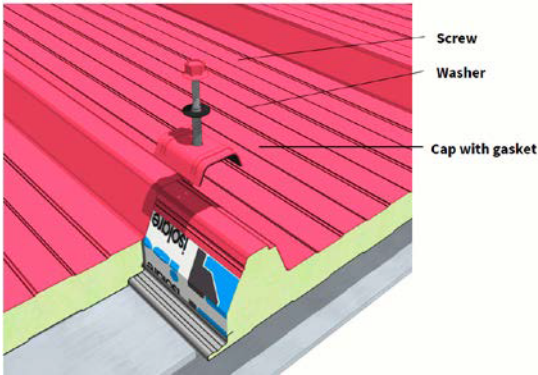

FIGURE 5 – ISOCOP4 PANEL ATTACHMENT DETAILS

Assembly sequence

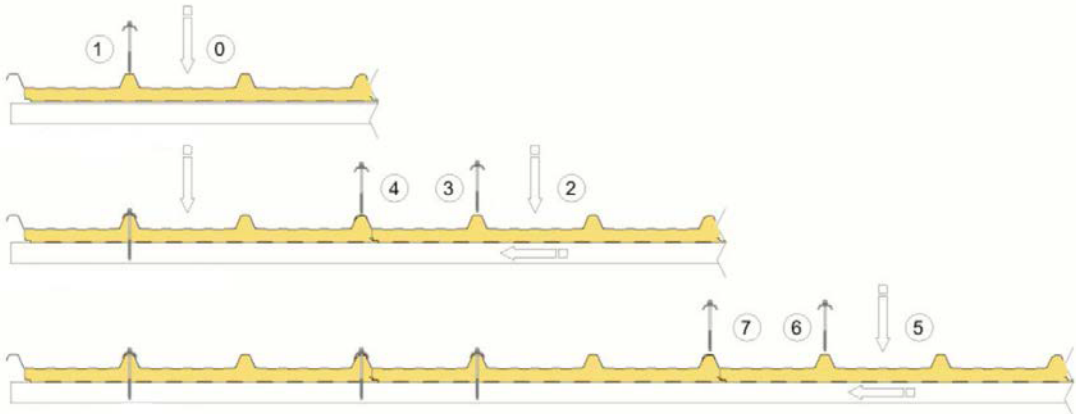
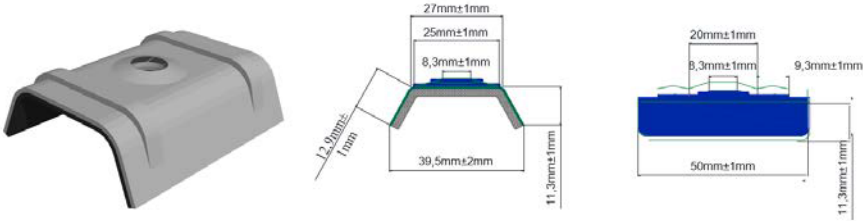

FIGURE 6 – ISOCOP4 PANEL ASSEMBLY SEQUENCE



for SI: 1 inch = 25.4 mm

FIGURE 7 – ISOCOP4 SADDLE CLIP





Issued November 2022

This report is subject to renewal November 2023.

DIVISION: 07 00 00—THERMAL AND MOISTURE PROTECTION

Section: 07 40 00 – Roofing and Siding Panels

REPORT HOLDER:  
ISOCINDU SA DE CV

EVALUATION SUBJECT:

ISOPARATE INSULATED METAL WALL PANELS (BOX, PLISSÉ, PIANO)  
ISOCOP4 INSULATED METAL ROOF PANELS

## 1.0 REPORT PURPOSE AND SCOPE

### Purpose:

The purpose of this evaluation report supplement is to indicate that the Isoparete Insulated Metal Wall Panels and Isocop4 Insulated Metal Roof Panels, described in ICC-ES evaluation report ESR-4659, have also been evaluated for compliance with the code noted below.

### Applicable code edition:

- ▶ 2020 Florida Building Code—Building

For evaluation of applicable chapters adopted by the California Office of Statewide Health Planning and Development (OSHPD) AKA: California Department of Health Care Access and Information (HCAI) and the Division of State Architect (DSA), see Sections 2.1.1 and 2.1.2 below.

## 2.0 CONCLUSIONS

### 2.1 CBC:

The Isoparete Insulated Metal Wall Panels and Isocop4 Insulated Metal Roof Panels, described in Sections 2.0 through 7.0 of the evaluation report ESR-4659, comply with CBC Chapters 14, 15, 16 and 26, provided the design and installation are in accordance with the 2021 and 2018 International Building Code® (IBC) provisions noted in the evaluation report and the additional requirements of CBC Chapters 15, 16, 17 and 26, as applicable:

**2.1.1 OSHPD:** The Isoparete Insulated Metal Wall Panels and Isocop4 Insulated Metal Roof Panels, described in Sections 2.0 through 7.0 of the evaluation report ESR-4659, comply with CBC amended Chapters 14, 15, 16 and 26, and Chapter 16A, provided the design and installation are in accordance with the 2021 and 2018 International Building Code® (IBC) provisions noted in the evaluation report, as applicable and the additional requirements in Sections 2.1.1.1 and 2.1.1.2 of this supplement:

**2.1.1 OSHPD:**

- ▶ The evaluation of the roof panel as a support, for the effects of photovoltaic panel attachments, in accordance with 2022 CBC Section 1511.9.1 [OSHPD 1, 1R, 2, 4 & 5] is outside the scope of this report.
- ▶ All loads applied shall be determined by a registered structural engineer and shall comply with applicable loads from CBC Chapter 16 [OSHPD 3] and its applicable amendments [OSHPD 1R, 2 and 5], and Chapter 16A [1 and 4].

**2.1.1.2 Special Inspection Requirements:**

Special inspections for Wind-Resisting Components must be provided in accordance with 2022 CBC Section 1705.12.3 (2019 CBC Section 1705.11.3) [OSHPD 1R, 2, 3, and 5] and 2022 CBC Section 1705A.12.3 (2019 CBC Section 1705A.11.3) [OSHPD 1 and 4], as applicable.

**2.1.2 DSA:** The Isoparete Insulated Metal Wall Panels and Isocop4 Insulated Metal Roof Panels, described in Sections 2.0 through 7.0 of the evaluation report ESR-4659, comply with CBC amended Chapters 15, 16 and 26, and Chapter 16A, provided the design and installation are in accordance with the 2018 and 2021 International Building Code® (IBC) provisions noted in the evaluation report, as applicable and the additional requirements in Sections 2.1.2.1 and 2.1.2.2 of this supplement:

**2.1.2.1 Conditions of Use**

- ▶ The evaluation of the roof panel as a support, for the effects of photovoltaic panel attachments, in accordance with 2022 CBC Section 1511.9.1 [DSA-SS, DSA-SS/CC] is outside the scope of this report.
- ▶ All loads applied shall be determined by a registered structural engineer and shall comply with applicable loads from applicable sections of CBC Chapter and its applicable amendments [DSA-SS/CC], and Chapter 16A [DSA-SS].

**2.1.2.2 Special Inspection Requirements:**

- ▶ Special inspections for Wind-Resisting Components must be provided in accordance with 2022 CBC Section 1705A.12.3 (2019 CBC Section 1705A.11.3) [DSA-SS and DSA-SS/CC].

This supplement expires concurrently with the evaluation report, issued November 2022.



Issued November 2022

[www.icc-es.org](http://www.icc-es.org)

This report is subject to renewal November 2023.

DIVISION: 07 00 00—THERMAL AND MOISTURE PROTECTION

Section: 07 40 00 — Roofing and Siding Panels

REPORT HOLDER:

ISOCINDU SA DE CV

EVALUATION SUBJECT:

ISOPARATE INSULATED METAL WALL PANELS (BOX, PLISSÉ, PIANO)  
ISOCOP4 INSULATED METAL ROOF PANELS

## 1.0 REPORT PURPOSE AND SCOPE

### Purpose:

The purpose of this evaluation report supplement is to indicate that the Isoparete Insulated Metal Wall Panels and Isocop4 Insulated Metal Roof Panels, described in ICC-ES evaluation report ESR-4659, have also been evaluated for compliance with the code noted below.

### Applicable code edition:

- ▶ 2020 Florida Building Code—Building

## 2.0 CONCLUSIONS

The Isoparete Insulated Metal Wall Panels and Isocop4 Insulated Metal Roof Panels, described in Sections 2.0 through 7.0 of ICC-ES evaluation report ESR-4659, comply with the 2020 Florida Building Code—Building. The design requirements shall be determined in accordance with the Florida Building Code—Building, as applicable. The installation requirements noted in ICC-ES evaluation report ESR-4659 for the 2018 International Building Code® meet the requirements of the Florida Building Code—Building, as applicable, with the following conditions:

1. Installation of the foam plastic (Isoparete Insulated Metal Wall Panels) in areas subject to damage from termites must meet the requirements of Section 1403.8 and 2603.8 of the Florida Building Code—Building.
2. The Isocop4 Insulated Metal Roof Panels, can be used as a component of a Class A roof covering assembly when installed in accordance with Section 4.3 of the ICC-ES evaluation report ESR-4659.

Use of the Isoparete Insulated Metal Wall Panels and Isocop4 Insulated Metal Roof Panels for compliance with the High Velocity Hurricane Zone provisions of the Florida Building Code—Building has not been evaluated and is outside the scope of this supplemental report. For products falling under Florida Rule 61G20-3, verification that the report holder's quality assurance program is audited by a quality assurance entity approved by the Florida Building Commission for the type of inspections being conducted is the responsibility of an approved validation entity (or the code official when the report holder does not possess an approval by the Commission). This supplement expires concurrently with the evaluation report, issued November 2022.



### ISOCOP4 ROOF PANEL WIND MAP

- 2" ISOCOP4 ROOF PANEL\*\*
- 4" ISOCOP4 ROOF PANEL\*\*
- 8" ISOCOP4 ROOF PANEL\*\*

**\*\*ASSUMPTIONS:**

- 1) RISK CATEGORY II - 60 FT TALL BUILDING IN EXPOSURE CAT C - ENCLOSED BUILDING.
- 2) BASED ON 4 FT MULTI-SPAN
- 3) ROOF SNOW LOAD MIGHT CONTROL THICKNESS OF THE ROOF PANEL.

THIS MAP IS FOR GENERAL GUIDANCE OF WHERE THESE PANEL CAN BE USED. ALL THE PANELS ARE SUBJECT TO STRUCTURAL ENGINEERING EVALUATION FOR THE INDIVIDUAL BUILDING LOCATION AND DIMENSIONS. PLEASE CONSULT WITH STRUCTURAL ENGINEER FOR ANY CASES OUTSIDE OF THE ASSUMPTIONS LISTED ABOVE, SUCH AS:

- RISK CATEGORY III OR IV, OR
- BUILDING HEIGHT ABOVE 60 FT OR
- WHERE SNOW LOAD MIGHT CONTROL OR
- FOR WIND AREA WITH WIND SPEED GREATER THAN 120 MPH

